

T0010511 LEG LIFT WITH PULL-UP

T0010511 LEG LIFT WITH PULL-UP

VISTA TRIDIMENSIONALE

THREE-DIMENSIONAL VIEW

SCHEDA TECNICA (TECHNICAL DATA SHEET)		
ART. T0010511	06-06-2024	SCALA (SCALE)
LE MISURE SONO ESPRESSE IN MM. (MEASUREMENTS ARE EXPRESSED IN MM.)		
 <small>TIEGI</small> <small>1911 PARTS & METTRES WORLD</small>	TIEGI SRL VIA BENEDETTO CROCE 7, Z.I. "CONDOTTI BARDINI", 31058 SUSEGANA (TV), 0438-460519	FOGLIO 1 DI 5

PIANTA (PLAN)

3800

4500

1500

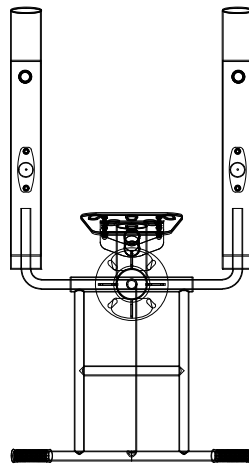

800

AREA DI SICUREZZA (SECURITY AREA) 18 MQ

SCHEDA TECNICA (TECHNICAL DATA SHEET)

ART. T0010511

06-06-2024

SCALA (SCALE)

LE MISURE SONO ESPRESSE IN MM. (MEASUREMENTS ARE EXPRESSED IN MM.)



TIEGI SRL
VIA BENEDETTO CROCE 7,
Z.I. "CONDOTTI BARDINI",
31058 SUSEGANA (TV),
0438-460519

FOGLIO 2 DI 5



ALTEZZA DI CADUTA MAX.
(MAX. FALL HEIGHT): <150 cm



INGOMBRO (OVERALL DIMENSION)
150 cm X 80 cm X 260 cm H.



NUMERO UTILIZZATORI 2
(MAX N. OF SIMULTANEOUS USERS)



AREA DI SICUREZZA (SECURITY AREA)
380 cm X 450 cm



SUP. ANTITRAUMA CONSIGLIATA
(RECOMMENDED SAFETY SURFACING AREA)
18 MQ.



ALTEZZA D'USO (USE HEIGHT)
>140 cm

SCHEDA TECNICA (TECHNICAL DATA SHEET)

ART. T0010511

06-06-2024

SCALA (SCALE)

LE MISURE SONO ESPRESSE IN MM. (MEASUREMENTS ARE EXPRESSED IN MM.)



TIEGI SRL
VIA BENEDETTO CROCE 7,
Z.I. "CONDOTTI BARDINI",
31058 SUSEGANA (TV)
0438-460519

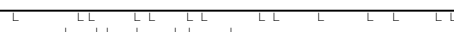

FOGLIO 3 DI 5

**MANOPOLE ZIGRINATE
IN GOMMA** (RUBBER KNURLED
HANDLES)

**L'ATTREZZO È PROVVISORIO DI QR
CODE PER LA VISIONE DI VIDEO
ESPLICATIVO D'USO** (THE EQUIPMENT
IS PROVIDED WITH A QR CODE, DISPLAYING AN
EXPLANATORY VIDEO OF THE EXERCISE)

**PIASTRE E LAMIERE IN
METALLO CON PROCESSO
DI VERNICIATURA DI
CATAFORESI, PRIMER E
VERNICIATURA
TERMOINDURENTE 180°C**
(METAL PLATES WITH CATAPHORESIS,
PRIMER AND 180°C THERMOSETTING
PAINT PROCESS APPLIED)

SCHIENALE IN HDPE
(HDPE BACKREST)

**TUBI IN METALLO
CURVATI. PROCESSO DI
VERNICIATURA PER
CATAFORESI, PRIMER E
VERNICIATURA
TERMOINDURENTE
180°C**
(CURVED METAL TUBES.
CATAPHORESIS, PRIMER AND 180°C
THERMOSETTING PAINT PROCESS
APPLIED)

**TUTTI GLI ELEMENTI DI FISSAGGIO,
VITI, DADI, RONDELLE ECC. SONO IN
ACCIAIO INOX**
(ALL FASTENERS, SCREWS, NUTS, WASHERS, ETC. ARE
MADE OF STAINLESS STEEL)

SCHEMA TECNICO (TECHNICAL DATA SHEET)

ART. T0010511

06-06-2024

SCALA (SCALE)

LE MISURE SONO ESPRESSE IN MM. (MEASUREMENTS ARE EXPRESSED IN MM.)



TIEGI SRL
VIA BENEDETTO CROCE 7,
Z.I. "CONDOTTI BARDINI",
31058 SUSEGANA (TV)
0438-460519

FOGLIO 4 DI 5

VISTA FRONTALE
(FRONTAL VIEW)

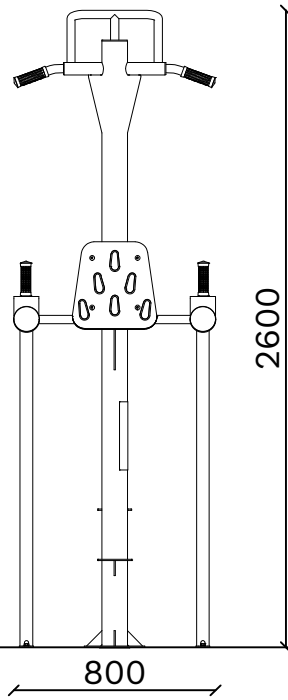

ALTEZZA MASSIMA DI
CADUTA LIBERA
(MAXIMUM HEIGHT OF THE
FREE FALL): < 150 cm

VISTA LATERALE
(LATERAL VIEW)

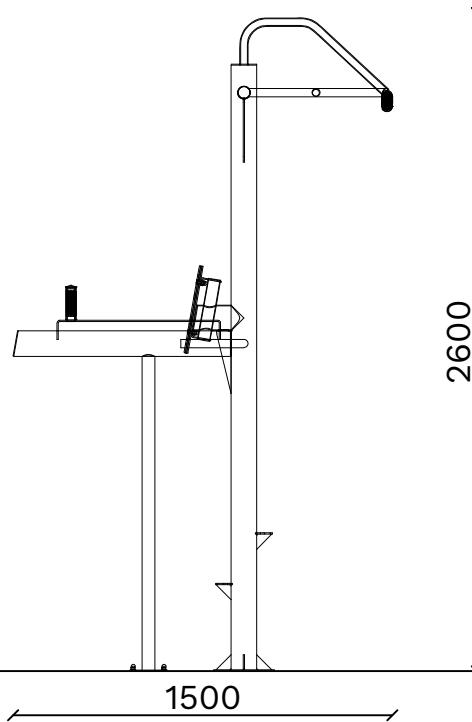

INGOMBRO MAX (OVERALL DIMENSIONS)

SCHEMA TECNICA (TECHNICAL DATA SHEET)		
ART. T0010511	06-06-2024	SCALA (SCALE)
LE MISURE SONO ESPRESSE IN MM. (MEASUREMENTS ARE EXPRESSED IN MM.)		
	TIEGI SRL VIA BENEDETTO CROCE 7, Z.I. "CONDOTTI BARDINI", 31058 SUSEGANA (TV) 0438-460519	FOGLIO 5 DI 5